



PENKO Engineering BV

The Leading Experts In Weighing & Dosing

10kg—50kg **IBM**

APPLICATIONS

The IBM-IP67 model is specially designed for platforms up to 400mm x 400mm with low profile and is protected from environmental conditions that appear in industry, where work and cleaning require a good environmental protection.



APPLICATION:

Mono-cell scales whose platform is up to 400mm x 400mm

CAPACITY RANGE:

10kg - 15kg - 20kg - 30kg - 50kg

MATERIAL:

Stainless Steel

ENVIRONMENTAL PROTECTION:

IP67

APPROVALS:

CE 3000 Div - TC6178

OIML 3000 Div - R60/2000-NL 1-03.03

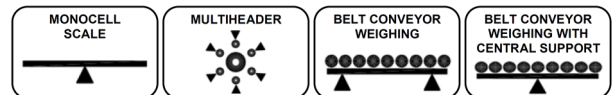
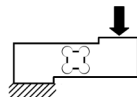

OPTIONS

Sensitivity alignment: $\pm 0,1\%$.

Length of the cable is optional.

Contact PENKO +31 318-525630 for special requirements.

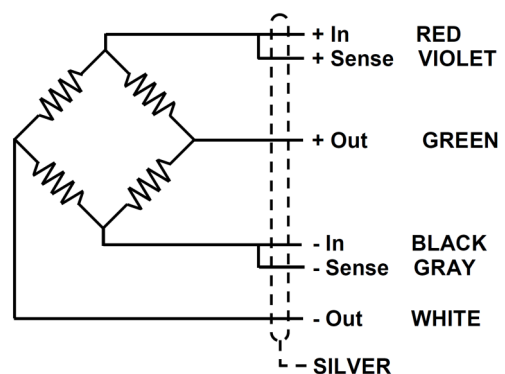
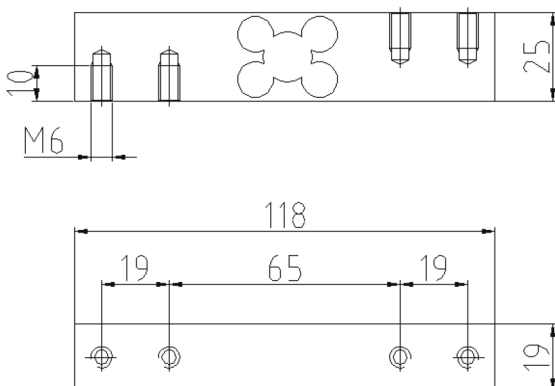

Dimensions in mm

