



PENKO Engineering BV

The Leading Experts In Weighing & Dosing

250kg-2000kg **SB9**



Product Description

The type SB9 is a stainless steel shear beam load cell with a high performance potting for superior environmental protection.

Application

- Platform scales, small hopper and tank weighing systems

Key Features

- Wide range of capacities from 250 kg to 2 500 kg
- Stainless steel construction
- Environmental Protection IP67
- Low profile design
- Unique blind loading hole (BH version only)
- Calibration in mV/V/Ω

Approvals

- OIML approval to C3 (Y = 10 000)

Packed Weight

- Appr. 1.2 kg

Available Accessories

- Compatible range of application hardware
- Compatible range of electronics available

Wiring

- The load cell is provided with a shielded, 6 conductor cable (AWG 26). Cable jacket polyurethane
- Cable length: 3 m
- Cable diameter: 5.8 mm
- The shield is connected to the load cell body

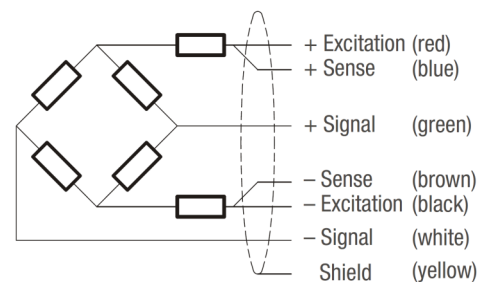

Load cell SB9: 250kg-2000kg

Technical Data

Specifications

Maximum capacity	(E _{max})	kg	250 / 500 / 1 000 / 2 000	
Accuracy class according to OIML R60			(GP)	C3
Maximum number of verification intervals	(n _{max})		n.a.	3 000
Minimum load cell verification interval	(v _{min})		n.a.	E _{max} / 10 000
Temperature effect on minimum dead load output	(TC ₀)	%*R ₀ /10°C	≤ ± 0.0400	≤ ± 0.0140
Temperature effect on sensitivity	(TC _{R0})	%*R ₀ /10°C	≤ ± 0.0200	≤ ± 0.0100
Combined error		%*R ₀	≤ ± 0.0500	≤ ± 0.0200
Non-linearity		%*R ₀	≤ ± 0.0400	≤ ± 0.0166
Hysteresis		%*R ₀	≤ ± 0.0400	≤ ± 0.0166
Creep error (30 minutes) / DR		%*R ₀	≤ ± 0.0600	≤ ± 0.0166
Rated Output	(R ₀)	mV/V	2 ± 0.1%	
Calibration in mV/V/Ω (A...I classified)		%	≤ ± 0.05 (≤ ± 0.005)	
Zero balance		%*R ₀	≤ ± 5	
Excitation voltage		V	5...15	
Input resistance	(R _{LC})	Ω	380 ± 10	
Output resistance	(R _{out})	Ω	350 ± 3	
Insulation resistance (100 V DC)		MΩ	≥ 5 000	
Safe load limit	(E _{lim})	%*E _{max}	200	
Ultimate load		%*E _{max}	300	
Safe side load		%*E _{max}	100	
Compensated temperature range		°C	-10...+40	
Operating temperature range		°C	-40...+65	
Load cell material			stainless steel 17-4 PH (1.4548)	
Sealing			potted	
Protection according EN 60 529			IP67	

The limits for Non-Linearity, Hysteresis, and TC_{R0} are typical values.

The sum of Non-linearity, Hysteresis and TC_{R0} meets the requirements according to OIML R60 with p_{LC}=0.7.

Dimensions (in mm)

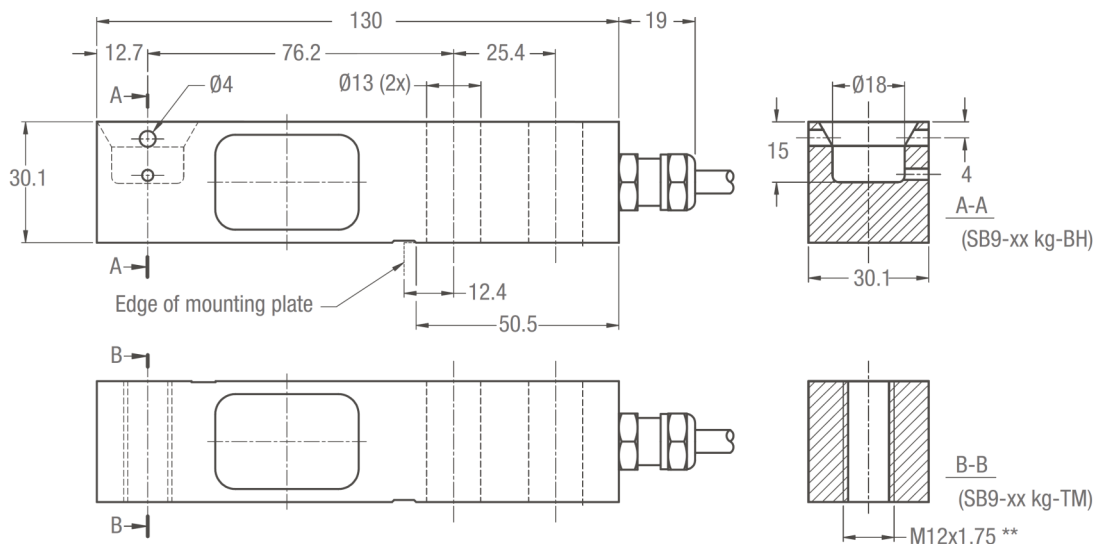

For maximum capacity from 250 kg to 1000 kg: Mounting bolts M12 8.8; torque 90 Nm
 For maximum capacity of 2000 kg: Mounting bolts M12 10.9; torque 120 Nm
 Torque values assume oiled thread.

** Unified thread 1/2-20 UNF is available. Type designation SB9-xx kg-TU.