



PENKO Engineering BV

The Leading Experts In Weighing & Dosing

45klbs-100klbs **SB2**



Product Description

The type SB2 is a steel shear beam load cell with complete hermetic sealing. Humidity resistant coating enables this load cell to be used in industrial environments.

Application

- Weighbridges, platform scales, hopper and tank weighing systems

Key Features

- Capacities of 45 klb and 100 klb (20.4 t and 45.4 t)
- Painted steel construction
- Environmental Protection IP68 with complete hermetic sealing
- Unique blind loading hole
- Calibration in mV/V/Ω

Approvals

- OIML approval to C1 (Y = 5 000) and C3 (Y = 15 000)
- ATEX hazardous area approval for Zone 0, 1, 2, 20, 21 and 22
- FM hazardous area approval

Packed Weight

■ Capacity (klb)	45	100
Weight (kg)	11.8	36.8

Available Accessories

- Compatible range of application hardware
- Compatible range of electronics

Wiring

- The load cell is provided with a shielded, 4 conductor cable (AWG 20). Cable jacket polyurethane
- Cable length: 9.1 m for 45 klb
10.7 m for 100 klb
- Cable diameter: 7.6 mm
- The shield is floating
(On request the shield can be connected to the load cell body)

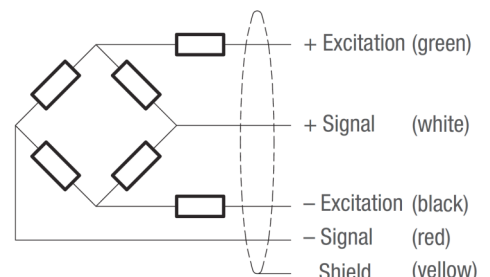

Specifications					
Maximum capacity	(E _{max})	lb	45 000 / 100 000		
Metric equivalents (1 lb=0.45359 kg)		t	20.4 / 45.4		
Accuracy class according to OIML R60			GP	C1	C3
Maximum number of verification intervals	(n _{max})		n.a.	1 000	3 000
Minimum load cell verification interval	(v _{min})		n.a.	E _{max} / 5 000	E _{max} / 15 000
Temperature effect on minimum dead load output	(TC ₀)	%*RO/10°C	≤ ± 0.0400	≤ ± 0.0275	≤ ± 0.0122
Temperature effect on sensitivity	(TC _{RO})	%*RO/10°C	≤ ± 0.0200	≤ ± 0.0160	≤ ± 0.0100
Combined error		%*RO	≤ ± 0.0500	≤ ± 0.0300	≤ ± 0.0200
Non-linearity		%*RO	≤ ± 0.0400	≤ ± 0.0300	≤ ± 0.0166
Hysteresis		%*RO	≤ ± 0.0400	≤ ± 0.0300	≤ ± 0.0166
Creep error (30 minutes) / DR		%*RO	≤ ± 0.0600	≤ ± 0.0490	≤ ± 0.0166
Rated Output	(RO)	mV/V	2 ± 0.1%		
Calibration in mV/V/Ω (A...I classified)		%	≤ ± 0.05 (≤ ± 0.005)		
Zero balance		%*RO	≤ ± 5		
Excitation voltage		V	5...15		
Input resistance	(R _{LC})	Ω	385 ± 20		
Output resistance	(R _{out})	Ω	351 ± 1		
Insulation resistance (100 V DC)		MΩ	≥ 5 000		
Safe load limit	(E _{lim})	%*E _{max}	200		
Ultimate load		%*E _{max}	300		
Safe side load		%*E _{max}	100		
Compensated temperature range		°C	-10...+40		
Operating temperature range		°C	-40...+80 (ATEX -40...+60)		
Load cell material			tool steel; painted		
Sealing			complete hermetic sealing; cable entry sealed by glass to metal header		
Protection according EN 60 529			IP68 (up to 2 m water depth) / IP69K		

The limits for Non-Linearity, Hysteresis, and TC_{RO} are typical values.
 The sum of Non-linearity, Hysteresis and TC_{RO} meets the requirements according to OIML R60 with p_{LC}=0.7.

Dimensions (in mm)

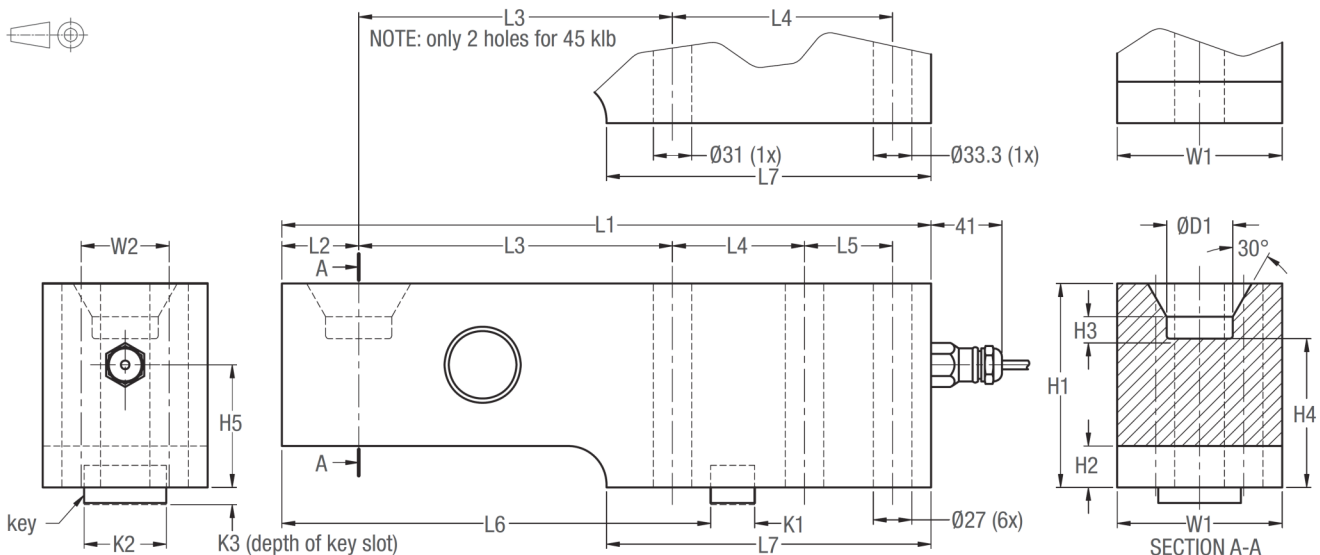

Type	L1	L2	L3	L4	L5	L6	L7	H1	H2	H3	H4	H5	W1	W2	D1	K1	K2	K3	Mounting bolts	Torque *
SB2-45 klb	318	38	159	89	n.a.	n.a.	159	95	27	12	73	61	70	n.a.	38.1	n.a.	n.a.	n.a.	M30 8.8	1500 Nm
SB2-45 klb-M	318	38	159	89	n.a.	n.a.	148	82	12	12	58	47	70	n.a.	38.1	n.a.	n.a.	n.a.	M30 8.8	1500 Nm
SB2-100 klb	416	48	197	92	54	276	210	143	41	14	111	92	95	54	50.8	25.4	47.6	10	M24 8.8	750 Nm

* Torque values assume oiled threads.

