

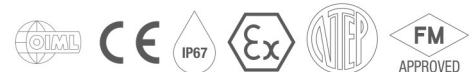

PENKO Engineering BV

The Leading Experts In Weighing & Dosing
200Kg-2000Kg

BK2



Product Description

The type BK2 is a stainless steel shear beam load cell with an improved potting. It is suitable for use in industrial environments.

Application

- Platform scales, small hopper and tank scales

Key Features

- Wide range of capacities from 200 kg to 2000 kg
- Stainless steel construction
- Environmental Protection IP67
- Very low profile design
- High input resistance
- Calibration in mV/V/Ω

Approvals

- For 500...2000 kg:
OIML approval to C3 (Y = 10 000)
- NTEP approval to 5 000 intervals, Class III
- ATEX hazardous area approval for Zone 0, 1, 2, 20, 21 and 22
- FM hazardous area approval

Packed Weight

Capacity (kg)	200	500	1000	2000
Weight (kg)	0.67	0.74	0.82	0.99

Available Accessories

- Compatible range of application hardware
- Compatible range of electronics

Wiring

- The load cell is provided with a shielded, 4 conductor cable (AWG 24).
Cable jacket polyurethane
- Cable length: 3 m
- Cable diameter: 5 mm
- The shield is floating
(On request the shield can be connected to the load cell body)

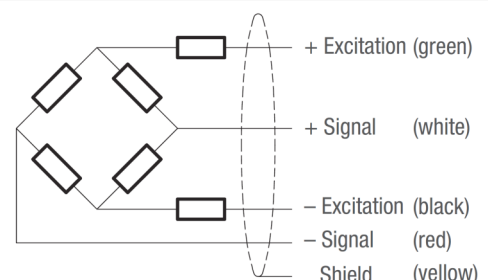

Specifications

	(E _{max})	kg	200 / 500 / 1 000 / 2 000	500 / 1 000 / 2 000
Maximum capacity			(GP)	C3
Accuracy class according to OIML R60			n.a.	3 000
Maximum number of verification intervals	(n _{max})		n.a.	E _{max} /10 000
Minimum load cell verification interval	(v _{min})		n.a.	
Temperature effect on minimum dead load output	(TC ₀)	%*RO/10°C	≤ ± 0.0400	≤ ± 0.0140
Temperature effect on sensitivity	(TC _{RO})	%*RO/10°C	≤ ± 0.0200	≤ ± 0.0100
Combined error		%*RO	≤ ± 0.0500	≤ ± 0.0200
Non-linearity		%*RO	≤ ± 0.0400	≤ ± 0.0166
Hysteresis		%*RO	≤ ± 0.0400	≤ ± 0.0166
Creep error (30 minutes) / DR		%*RO	≤ ± 0.0600	≤ ± 0.0166
Rated Output	(RO)	mV/V	2 ± 0.1%	
Calibration in mV/V/Ω (A...I classified)		%	≤ ± 0.05 (≤ ± 0.005)	
Zero balance		%*RO	≤ ± 5	
Excitation voltage		V	5...15	
Input resistance	(R _{LC})	Ω	1 100 ± 50	
Output resistance	(R _{out})	Ω	1 000 ± 2	
Insulation resistance (100 V DC)		MΩ	≥ 5 000	
Safe load limit	(E _{lim})	%*E _{max}	200	
Ultimate load		%*E _{max}	300	
Safe side load		%*E _{max}	100	
Compensated temperature range		°C	-10...+40	
Operating temperature range		°C	-20...+65 (ATEX -20...+60)	
Load cell material			stainless steel 17-4 PH (1.4548)	
Sealing			potted	
Protection according EN 60 529			IP67	

The limits for Non-Linearity, Hysteresis, and TC_{RO} are typical values.
The sum of Non-linearity, Hysteresis and TC_{RO} meets the requirements according to OIML R60 with p_{LC}=0.7.

Dimensions (in mm)

Type	H	Mounting bolts	Torque**
BK2-200 kg	12.7	M12 8.8	90 Nm
BK2-500 kg	15.9	M12 8.8	90 Nm
BK2-1000 kg	19.1	M12 8.8	90 Nm
BK2-2000 kg	25.4	M12 10.9	120 Nm

** Torque values assume oiled threads.

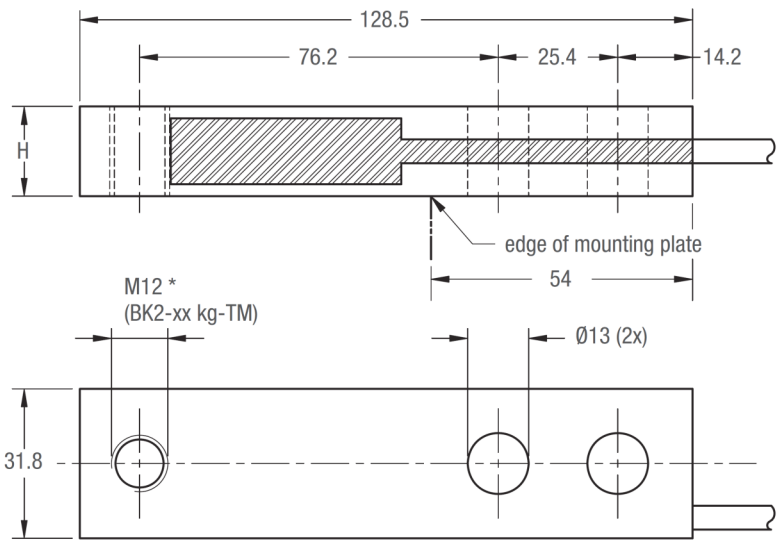

* Unified thread 1/2-20 UNF is available (BK2-xx kg-TU-Cx).